



**LALIZAS**



# SEAJET

## SAFELY AND EFFICIENTLY DELIVERING SEAWATER TO MEET YOUR DAILY NEEDS



HOUSTON • HOUMA

*SeaJet is a lightweight water intake delivery system designed to deliver seawater at a maximum rate of 4,000 gpm. SeaJet replaces high maintenance and heavier water delivery towers through increasing variable deck load and minimizing deck space consumption. The SeaJet system arrives assembled and ready to be installed either dockside or onsite. Our technical support team is ready to speak with you.*



# Deep Well Sea Jet System

Safely Delivering Seawater to Your Offshore Rig

## FEATURES & BENEFITS

- **SAFE:** Allows safe deployment and recovery of submersible deep well pumps.
- **ONE-MAN OPERATION:** Easy to use and quick infield maintenance.
- **MODULAR DESIGN:** allows quick and easy changes of the components.
- **WEIGHT REDUCTION:** The SEAJET is significantly lighter than any other delivery system on the market
- **VDL:** Increased Variable Deck Load capacity by removing heavy towers and associated piping.
- **SAVES SPACE:** Much smaller footprint than any other delivery system.
- **EASY MAINTENANCE:** Replaces high maintenance and heavier water delivery towers.
- **EFFECTIVE:** Seawater delivery pump rates can be configured to deliver 4,000 GPM.
- **DURABLE & SIMPLE:** Designed to withstand the harsh seawater environment.

## SYSTEM DESCRIPTION

The **SEAJET** is a seawater system designed to eliminate the hazards and inefficiencies associated with current delivery systems. **SEAJET** is a lightweight system utilizes technology to minimize weight and space consumption. Seawater is delivered to elevated structures through a unique compact flexible hose deployed from the **SEAJET** reel system. The pump is attached to one end of the hose bundle and lowered into the water by the **SEAJET**.

Powered utilizing electric rig power. The specially designed hose bundle incorporating tension cable and pump electrical power cable. Every metal part of the **SEAJET** in contact with the water is constructed of stainless steel.

Bolts are Grade 8 coated. The system is operated by one person and is mounted at deck edge or at the existing tower location. Access to the reels for maintenance is easily done from the side. Each reel and hose bundle system weighs only 5 tons with a small footprint of 7-ft (W) x 11-ft (L).



# Deep Well Sea Jet System

Safely Delivering Seawater to Your Offshore Rig



<b>Delivery</b>	SEAJET delivers seawater utilizing submersible pumps ranging from 60hp to 250. Delivery capacity will depend on pump size and elevation (air gap).
<b>Unit Size</b>	Compact 7-ft (width) x 11-ft (length) x 10.6-ft (height) per reel.
<b>Unit Weight</b>	10,000 lbs per reel with hose.
<b>Reel</b>	Reinforced drum holds a hose bundle totaling 9 ft diameter when spooled.
<b>Hose</b>	Two 4" high strength non-collapsing hoses with pump tension cable.
<b>Drive package</b>	Electric worm gear reducer provides 18,500 ft-lbs lifting torque.
<b>Hoisting Speed</b>	Pump is retrieved at a safe speed of 30 ft per minute.
<b>Brake</b>	Safe electro-mechanical braking design with additional manual parking locks.
<b>Control Panel</b>	Controls with indicator lights and pump soft start in a stainless steel NEMA 4 box to operate deepwell pump and reel. Safety devices include warning lights, emergency stop feature, manual disconnect electrical door latch interlock.

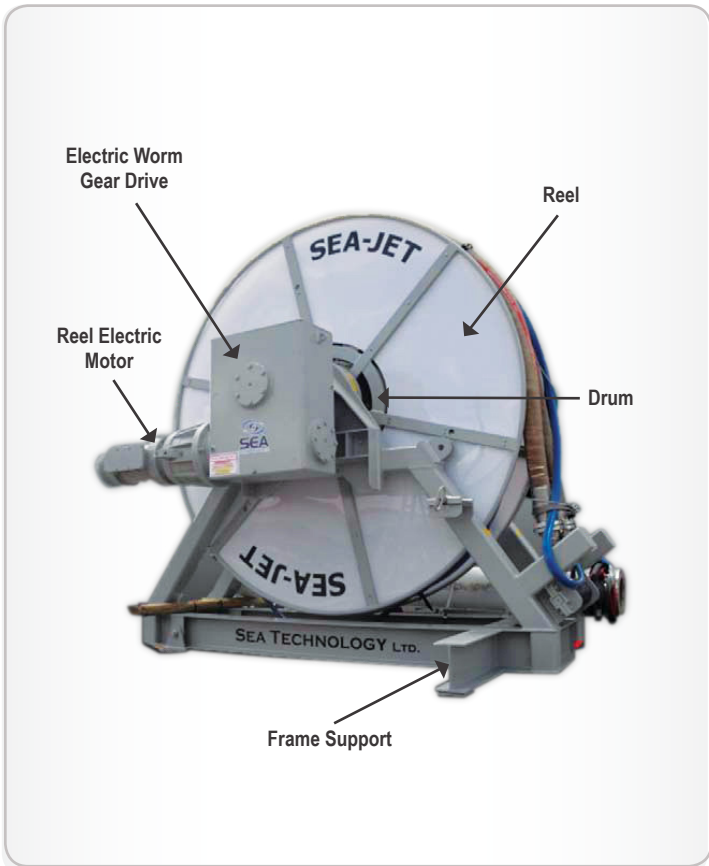

# SEAJET

## Equipment Specifications

### Motor Drive

13 hp electric motor TENV

480V / 60Hz / 3 Phase / Rated Current 27.3A

Stall Torque = 32,200 ft-lbs

Starting Torque = 25,550 ft-lbs

### Motor Control

Electrical controller for reel motor drive inside Control Panel. Pump hp will determine the size of the multi purpose control panel.

### Gear Reducer

Right angle gear reducer.

18,500 ft-lbs running torque.

### Brake & Drive

Worm gear prevents coasting. Manual parking locks.

### Hose Bundle

Flexible rubber cover and high strength tension cable.

Dual 4" ID x OS&D hoses, 250 psi WP, 1,000 psi.  
Test Certificates supplied for each hose

Hose material made of a nitrile tube and multiple fabric plies and a helical wire. An extra thick abrasion resistant jacket is standard. Spreaders maintain spacing of the hoses and assure correct winding. Pump electrical power wire is positioned between the hoses for protection

Hose bundle easily installs with standard oil field connections.

4" SS Victaulic connections and 4" SS flanges are permanently swaged on each end.

## ELECTRIC MOTOR & WORM GEAR DRIVE

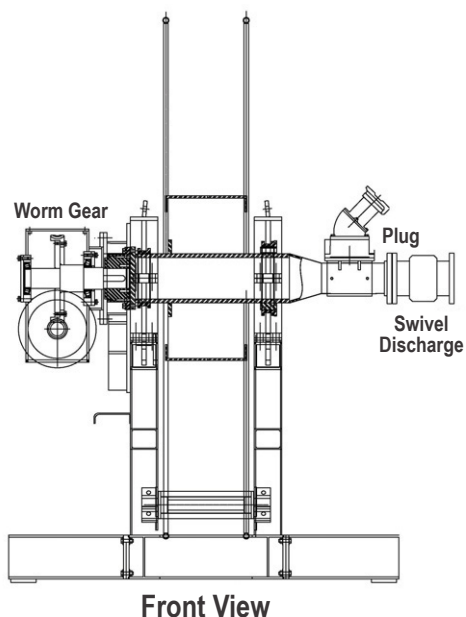

## LALIZAS / ALEXANDER

### Headquarters

Houston  
2000 Wayside Drive  
Houston, TX 77011  
United States  
713-923-1671

### Logistics Center

Houma  
205 East Woodlawn Ranch Road  
Houma, LA 70363  
United States  
985-333-5987



**LALIZAS**

e-mail: [armsseajet@alexanderryan.com](mailto:armsseajet@alexanderryan.com)

[www.alexanderryan.com](http://www.alexanderryan.com) | [www.lalizas.com](http://www.lalizas.com)